

AIR BOSS[®] KES SERIES

Kitchen Exhaust Filtration Systems



- INSTALLATION
- OPERATION
- SERVICE

Electrostatic Precipitator for Commercial Kitchens



101 McNeill Road • Sanford, NC 27330
(919) 775-2201 • Fax: (919) 777-6399 • (800) 884-0002
www.trioninc.com

MANUAL PART NO. 257045-001 – April 2004

TABLE OF CONTENTS

SECTION I – DESIGN

For The System Design Engineer

Page

- | | |
|-----------------------------|---|
| 1. General Description | 3 |
| 2. System Design and Layout | 3 |
| 3. Outdoor Installations | 4 |

SECTION II – INSTALLATION

For The Installing Contractor

- | | |
|--|---|
| 1. Unpack and Inspect | 5 |
| 2. Position Air Cleaner Cabinet | 5 |
| 3. Connect Adjoining Ductwork | 5 |
| 4. Connect Drain | 5 |
| 5. Remote Mounted Control Box
(Customer supplied or optional Trion component) | 5 |
| 6. Complete Wiring | |
| a. Primary Wiring | 5 |
| b. Grounding | 6 |
| 7. Checkout for System Start-up | 6 |

SECTION III - OPERATION AND SERVICE

For The Maintenance Engineer

- | | |
|--|----|
| 1. Introduction and Principle of Operation | 6 |
| 2. General Description | 6 |
| 3. Initial Start-up | 7 |
| 4. Routine Maintenance | 7 |
| 5. Periodic Maintenance | 8 |
| 6. Troubleshooting | 9 |
| 7. Spare Parts | 10 |
| 8. Troubleshooting Reference | 11 |

SECTION IV – REFERENCE

Illustrations and Drawings

- | | |
|--|----|
| Figure 1 KIT-AIRE Unit Outline | 12 |
| Figure 2 Typical Outdoor Installation | 13 |
| Figure 3 Field Wiring – Junction Box | 14 |
| Figure 4 Wiring Diagram –KES-2 | 15 |
| Figure 5 Wiring Diagram – KES-4 | 16 |
| Figure 6 Remote Mounted Control Box Schematic (Optional) | 17 |
| Figure 7 Parts List – Access Door Enclosure Components | 18 |
| Figure 8 Parts List – KES Cabinet Components | 19 |
| Contact Information | 20 |

SECTION I – DESIGN

FOR THE SYSTEM DESIGN ENGINEER

1. General Description

The standard major components supplied with each KES Kitchen Exhaust Filtration Systems are as follows:

- Electronic air cleaner/media absorber cabinet
- Power supply(s) and status LED(s)
- Junction Box

The electronic air cleaner cabinet contains split ionizer and collecting cells (collecting elements), perforated plate pre-filters and metal mesh after-filters. Perforated plates, in lieu of the metal after-filters, are optional when specified.

The standard electronic air cleaner cabinet is equipped with a Media Section for housing an optional 95% DOP – rigid pleat filter and/or an odor adsorption module.

Gasketed access doors located on one end of the cabinet, 90 degrees to the direction of the airflow, provide entry for removal of the cells and filters.

All KES cabinets are 2” [51mm] double wall insulated on the top and two sides and are welded to a 3” [76mm] unitary mounting rail.

The Pulse Width Modulated (PWM) power supply(s), providing the necessary high voltage for the air cleaner and power supply status LED(s), are furnished in an enclosure on the ionizer/cell access door.

The junction box is located on top of the cabinet and above the ionizer and collector cell access door. The junction box contains terminals for a single point wiring connection.

Other options available with the KES are as follows:

- Remote mounted control box containing an On/Off switch, power supply status light, relay for connection to an exhaust system, fan starter and power supply shut-down relay for a fire condition
- UL 762 fan for restaurant exhaust, suitable for outdoor installation
- Fire suppression pre-piping

2. System Design and Layout

The arrangement of the supplied components and the general layout of the system will vary according to application, adjoining equipment and available space. However, there are several basic factors pertaining to all installations that must be considered:

To maintain the selected cleaning efficiency, it is important to assure that the total air volume (capacity in CFM) is uniformly distributed across the entire face area of the unit. The perforated plate and metal mesh filters provide some resistance to effect even air distribution. However, since most air ducts are designed to handle air velocities greater than the rated velocity of the air cleaner, it is necessary to properly transition any attached ducting. If possible, a contraction ratio of 1 in 3 (approximately 20°) should be maintained.

If space prohibits, turning vanes, air baffles or other means may be utilized. Ducting, where attached to the cabinet collars, should be liquid-tight and in compliance with NFPA 96 and any other local code requirements.

Contaminants to be collected, such as oils in vaporous state, must be condensed into particulate form prior to entering the ionizer and collecting cells in order to maintain the anticipated efficiency. Gases, vapors or odors cannot be precipitated and will therefore pass through the air cleaner. Any condensing that takes place downstream from the air cleaner defeats the purpose. By the same token, heavy concentrations of water vapor, or other matter that becomes highly conductive when condensed, must be prevented from entering and/or condensing in the collecting elements to prevent electrical arc-over and shorting.

WARNING!
RISK OF ELECTRICAL SHOCK

Factory designed access to all electrically charged high voltage components contain electrical interlocks for the safety of operating personnel. These servicing instructions are for use by qualified personnel only. To reduce the risk of electric shock, do not perform any servicing other than that contained in the operating instructions unless you are qualified to do so.

Each KES system is supplied with two, 2" NPT cabinet drain couplings (see Figures 1 & 2). Each coupling is plugged at the factory. During installation, clearance to access these clean-out drain couplings must be considered. It is recommended that the drain couplings be piped off to an acceptable catch basin. Drain pipe lines from the cabinet drain should be trapped or otherwise sealed against the system pressure (in accordance with local codes). For ease in maintenance and component removal, adequate space, **32" [813mm] Minimum required**, must be provided in front of all access doors. Special consideration should be given in this respect for installations where the unit is suspended overhead. Catwalks or platforms should be provided.

CAUTION

In addition to the above space requirement, installation of the KES in NFPA applications shall have a clearance of at least 18" [457mm] to a combustible material, 3" [76mm] to limited combustible material, and 0" [0mm] to noncombustible material. Any reduction in clearance or exceptions must be in compliance with NFPA and acceptable to the AUTHORITY HAVING JURISDICTION.

WARNING!
FIRE SUPPRESSION SYSTEMS

Extreme caution should be exercised when this unit is installed in applications that are collecting volatile or potentially flammable contaminants such as cooking grease and petroleum based oils. **TRION STRONGLY RECOMMENDS A FIRE SUPPRESSION SYSTEM BE INSTALLED IN THE DUCTWORK AND ON THE KES IN CASES WHERE THESE CONTAMINATES ARE COLLECTED ON THE CELL PLATES AND COLLECT ON THE ATTACHED DUCTWORK.** Contact the factory for questions or concerns regarding a fire suppression system.

3. Outdoor Installations

The KES system is suitable for outdoor installation. Requirements for outdoor protection vary in accordance to climate and equipment component arrangement for the particular job. The installing contractor should treat the equipment as required to meet the specific needs. Detailed discussions of the KES components are as follows, using a rooftop installation as an example (refer to Figure 2):

Adjoining Duct Work (not supplied by Trion)
The ductwork located on the air entering side of the cabinet, between the point where it enters the roof and the cabinet, must be liquid-tight and installed in accordance with NFPA and any other local code requirements. It must also be adequately insulated or other means must be taken to prevent the formation of condensation through temperature change. Condensation will short out the ionizer and collecting cells. Insulation must be of the outdoor variety.

Trion KES Cabinet
The access doors on the KES cabinet are gasketed and the unit is sealed against air leakage. The paint finish (enamel) is for interior and exterior use. The cabinet is double-wall, weather-tight construction with 2"[51mm] thick-8 lb/ft³ [128 kg/m³] density mineral wool insulation on the top and two sides.

Drain Line
The drain line, when piped from the cabinet drain coupling, should be trapped or otherwise sealed against the system pressure and sloped to allow for maximum drainage. The drain line should be trapped to seal off the cabinet from the drain against the system pressure and should be located in the heated interior. Failure to provide sufficient slope on drain lines will result in poor drainage, pooling of liquid in the cabinet and possible system failure. Drain line pipe runs should be piped with as short a run as possible to the heated interior of the building, preferably straight down from the drain pan supply through the floor. If not installed in this manner, heat wrap or other means should be employed to prevent freezing. It is recommended that clean-outs be installed in all drain lines.

SECTION II – INSTALLATION

FOR THE INSTALLING CONTRACTOR

1. Unpack and Inspect

Upon receipt of the equipment, all shipping containers and their contents should be examined for damage. Any damage occurring in shipment must be immediately reported to the carrier, an inspection report completed and a claim filed at the receiving point.

The unit cabinet is shipped completely assembled with perforated plate pre-filter, ionizer, collector cell and metal mesh after-filter factory installed. Media (95% DOP rigid pleat) filter(s) and odor adsorption modules are shipped separately to prevent premature particulate loading and protect against damage during shipment. Optional fan package can be either factory installed with KES cabinet assembly or shipped separately.

2. Position Air Cleaner Cabinet

To reduce weight for ease in handling, remove the pre-filters, after-filters, ionizer(s) and collecting cells from the cabinet, and place them safely aside. Position the cabinet in the designated location giving consideration to the following points:

- A. Provide sufficient clearance in front of the access doors for ionizing-collecting cell and mechanical filter removal. **A minimum of 32 inches [813mm] is required. (see figure 2)**
- B. Level the cabinet to assure proper drainage from the drain pan.
- C. Direction of airflow through the cabinet is from **right-to-left** when looking at the access doors. After the cabinet has been properly located, it may be secured into place by bolting or welding.

3. Connect Adjoining Duct Work

When adjoining ducting is to be installed, the duct securement to the KES collars should be made liquid-tight and in compliance with NFPA requirements and any other local codes that apply.

When a blower (other than factory installed) is installed downstream from the KES cabinet, the ducting between the cabinet and the blower will be under negative pressure and should be made air-tight to prevent infiltration of contaminated air.

After the ductwork has been installed, clear remaining material or debris from inside ducts and bottom of cabinet, and then re-install the mechanical filters, ionizer(s) and collector cells.

IMPORTANT NOTE: Ionizer and collector cells are designed with a keyed slot permitting one directional installation into cabinet. When properly installed, the brass contact plungers on the ionizer and cell should be pointed toward the access door. Installation of the perforated plate pre-filter and either a perforated plate after-filter or metal mesh after-filter is required for all installations. After installation of the pre/after filters, ionizer and collector cells, the filter clip should be installed.

4. Connect Drain

Connect a drain line to the cabinet drain couplings provided in the cabinet drain basin in accordance with the governing plumbing codes. The drain line must be sealed with a trap or other means to prevent air bypass. If a trap is used, it should hold sufficient water column to overcome the system air pressure and to assure that loss of liquid from evaporation between cleaning periods will not break the seal. The drain line should not be smaller than the drainpipe coupling.

5. Remote Mounted Control Box (customer supplied or optional Trion component)

The remote mounted control box should be mounted at eye level and located in an accessible place for operator, maintenance and service personnel.

6. Complete Wiring

A. Primary Wiring

The junction box located on top of the KES is the main distribution point for primary wiring. A terminal block inside the junction is provided for single point wiring to the various electrical components. Main power disconnect and safety interlocking is achieved through a sealed, flex cable connector attached to the junction box. To prevent access to charged high voltage, this cable connector must be unscrewed (breaking the connection) from a mating, flange mounted connector on top of the ionizer and collector cell access door. Refer to Figure 3 on page 14 for Field Wiring Diagram.

B. *Grounding*

An earth ground must be provided to the KES cabinet and optional remote mounted control box. All ground connections must be in contact with bare metal and securely affixed. Ground conductor size and connection means will be in accordance with all applicable electrical code standards.

7. Check Out for System Start-up

When the installation has been completed, assure that the equipment is ready for start-up by checking the following:

A. All construction debris is removed from the KES cabinet, ionizer(s), collecting cells and adjoining ductwork.

B. The drain line from the KES drain couplings is clear and completely connected to its point of termination.

C. Supply line power is available and electrical wiring is completed to the following components:

- KES junction box
- Remote mounted control box
- System fan and starter
- Fire suppression panel

SECTION III - OPERATION & SERVICE

WARNING! RISK OF ELECTRIC SHOCK

These service instructions are for use by qualified personnel only. To reduce the risk of electric shock, do not perform any servicing other than that contained in the operating instructions unless you are qualified to do so.

FOR THE MAINTENANCE ENGINEER

1. Introduction and Principle of Operation

The electronic air cleaner is technically known as an electrostatic precipitator. In this type of equipment, all airborne particles, even of microscopic size, are electrically charged (positively) as they pass through a high voltage ionizer. These charged particles are then attracted and adhere to a series of parallel collecting plates, which form the negative elements of an electrostatic field.

The ionizer consists of charged Tungsten wire spaced between grounded electrodes. The collecting section consists of parallel plates arranged so that each alternate plate is charged while the

intermediate plates are electrically grounded.

Periodically, depending on the type and concentration of contamination in the air, contaminate is washed from the plates by manually removing the cells and cleaning them (pages 7 & 8, Item 4, A & B, Routine Maintenance).

Two major functional components comprise the air cleaner:

- (1) Ionizer and collecting cells to ionize and collect airborne particulate matter
- (2) Power supply(s) to supply high voltage direct current to the ionizing-collecting cells

Normally, systems are designed for collection efficiencies in the range of 90 percent or more. Collecting a contaminate at these efficiencies, especially when there are high concentrations, can result in large accumulations in a relatively short period. Therefore, maintenance must encompass two areas: the operation of the equipment for efficient collection, and the systematic removal of the collected contaminate.

2. General Description

The ionizer(s) & collecting cells (contaminant collecting elements) are housed in the cabinet on slide rails. They can be removed from the cabinet as required, through the access door, by sliding them out like drawers.

Ionizer-to-ionizer and collector cell-to-collector cell electrical connections are automatically made through spring plunger connectors. Power supply(s) on the ionizer/collector cell access door make contact with ionizer and collector cell spring plungers through an insulated high voltage contact.

IMPORTANT NOTE: Ionizer and collector cells are designed with a keyed slot permitting one directional installation into the cabinet. When properly installed, the brass contact plungers on the ionizer and cell should be pointed toward the access door.

Installation of the perforated plate pre-filter and either a perforated plate after-filter or metal mesh after-filter is required for all installations. These items act as trash screens and provide resistance for even air distribution. After installation of the pre/after filters, ionizer and collector cells, the filter clip should be installed.

The power supply(s) convert the 120/220-volt, 50/60HZ, single phase AC supply to the high voltage DC needed to power the ionizing-collecting cells. Potential of 12.5 –13.0 kVDC are required for the ionizer sections and 6.0 - 6.5 kVDC for the collector sections of the cells.

3. Initial Start-up

A. Inspect the inside of the adjoining ductwork and KES cabinet to be sure it is clean and free of any debris or construction materials. Ensure the openings in the drain basin are free of any restrictions. The ducting, where secured to the cabinet collars, should be sealed liquid tight in accordance with NFPA.

B. Inspect the ionizer and collecting cells to see that all of the ionizing wires are intact, no large pieces of foreign material are lodged between the plates, high voltage insulators are not cracked, and the ionizer and collecting cells are properly installed in the cabinet.

C. Check the primary wiring to see that it is connected to the proper terminal in both the KES junction box and the remote mounted control box. (Refer to Figures 3 and 6, pages 14 and 17).

D. Be sure the drain lines from the KES cabinet drain coupling are completely connected and properly terminated. A trap or seal should be incorporated in the line to prevent air bypass.

E. Be sure that electrical power is available, the wiring is completed, and the system blower is ready to energize.

F. Be sure the flex cable connector (main power disconnect/safety interlock) is aligned, pushed down and screwed securely into the mating flange mount connector on the access door. To help with alignment, marks have been placed on the flex cable connector body and the flange mount connector.

G. Close the system electrical supply switches, making power available to the remote mounted control box and the system fan.

H. Turn the control box selector switch to the “ON” position. The exhaust fan should run (if installed) and the power supply(s) should be energized. Electrical arcing within the collecting cells may occur. It is a normal occurrence caused by accumulation of dusts from construction or other sources in the cell(s) and should subside quickly. If

the arcing is continuous and does not subside, recheck the cell for trash, damaged plates or cracked insulators.

IMPORTANT NOTE: Kitchen exhaust fan control and operation will vary with each installation. The optional Trion remote mounted control box contains a 120/220VAC relay for connection to the exhaust fan starter coil. When the control box selector switch is placed in the “ON” position, the relay will energize the fan starter coil.

For safe and proper Kitchen Exhaust operations, adhere to the following instructions and procedures:

1. Exhaust systems shall be operated during all periods of cooking in restaurant applications.
2. Filter-equipped exhaust systems shall not be operated with filters removed.
3. The posted instructions for manually operating the fire extinguishing system shall be kept conspicuously posted in the kitchen and reviewed periodically with employees by the management.
4. Listed exhaust hoods shall be operated in accordance with the terms of their listings and the manufacturer instructions.
5. Cooking equipment shall not be operated while its fire-extinguishing system or exhaust system is not operating or otherwise impaired.

4. Routine Maintenance

A. Washing Frequency

The frequency the collected dirt must be manually washed from the unit depends upon the type and amount of dirt in the air to be cleaned. Dirt, which is greasy in nature, tends to harden after collection and should be washed away often. Likewise, units operating under extremely heavy dirt loads should be washed more often as a large build-up of collected material will have a tendency to “blow-off” if permitted to remain on the collecting elements for long periods of time. Trion recommends starting with a manual washing frequency of at least once a week. This schedule may then be altered as needed after visual examinations of the collected material contained on the ionizing-collecting cells. **Daily manual washing is not unusual for units operating on heavy kitchen exhaust hoods or similar contaminants.**

Manual washing to clean the perforated plate pre-filter, ionizer(s), collecting cells, and metal mesh or perforated plate after-filters can be performed in a soak tank, commercial car wash, or with a pressure hose or pressure cleaner using a low pressure setting. Particular care should be taken in cleaning each of the insulators.

WARNING!
DO NOT USE HIGH PRESSURE STEAM CLEANING EQUIPMENT TO CLEAN CELLS. THE EXCESSIVE HEAT AND PRESSURE WILL CAUSE THE PLATES TO WARP AND IN TURN POSSIBLY CAUSE EXCESSIVE ARCING.

WARNING!
FLAMMABLE SOLVENTS OR OTHER FLAMMABLE CLEANING AIDS SHALL NOT BE USED.

When a cleaning service is used, a certificate showing dates of inspection and/or cleaning shall be maintained on the premises.

B. Detergent

Effective washing is dependent upon detergent. The detergent, as supplied by Trion, Inc., is formulated specifically for electronic air cleaners. If substitutes are used, Trion must approve them in order not to void the warranty. Please contact Trion for this approval. Alternate detergents should be safe for use in ventilation systems and non-caustic, as 95% of the ionizer and collecting cells are constructed of aluminum and special high voltage insulation and gasket seals.

C. Media filter and odor adsorption module replacement (IF INSTALLED) – Every 3 to 6 Months

Units equipped with this option may experience different loading conditions and scheduled replacement may then be altered as needed after visual examination.

D. Electrical Operation

The KES and optional remote mounted control box both have LED indicating lights to show power to the PWM power supply(s) and output voltage present (12.5 – 13.0 kVDC ionizer and 6.0 – 6.5 kVDC collector). Flickering or failed LEDs indicate electrical arcing, electrical short and/or power failure.

5. Periodic Maintenance

A. Fire Suppression System (IF INSTALLED) – Every 6 Months

Properly trained and qualified personnel shall complete inspection, cleaning and servicing of the fire suppression system.

All actuation components, including remote manual pull stations, mechanical or electrical devices, detectors, fire-actuated dampers, etc., shall be checked for proper operation in accordance with the instructions in this manual. In addition to these requirements, the specific inspection requirements of the applicable NFPA standard shall also be followed. If required, certificates of inspection and maintenance shall be forwarded to the authority having jurisdiction.

B. KES Power Supply Enclosure - Every 12 Months

The KES power supply enclosure located on the ionizer/collector cell access door should be examined for accumulated dirt and dust. If required, the components should be cleaned using a good electrical contact cleaner. All terminal connections should be checked for securement and tightened or reworked as required.

WARNING!
Risk of Electrical Shock
To reduce the risk of electric shock, do not perform any servicing unless all electrical power to the system has been turned off.

At the start of the cleaning process, electrical switches that could be accidentally activated shall be locked out. Components of the fire suppression system (if installed) shall not be rendered inoperable during the cleaning process.

CAUTION
Care should be taken not to apply cleaning chemicals on any fusible links or other detection devices of the automatic extinguishing system.

6. Troubleshooting

WARNING!
EXERCISE THE USUAL PRECAUTIONS WHEN WORKING WITH HIGH VOLTAGE. THE MAXIMUM OPERATING OUTPUT FROM THE POWER SUPPLY IS 15,000 VDC AND 5.5 MA. TO 11.0 MA. WHEN IN PARALLEL.

IF SAFETY SWITCHES ARE CLOSED AND CIRCUIT IS ENERGIZED, DO NOT TOUCH HIGH VOLTAGE. WHEN THE CIRCUIT IS DE-ENERGIZED, ALWAYS BLEED OFF REMAINING STATIC CHARGE WITH AN INSULATED HANDLED SCREW DRIVER BY SHORTING TO GROUND THE POINTS OF HIGH VOLTAGE DC POTENTIAL.

WARNING!
Risk of Electrical Shock
The servicing Instructions are for use by qualified personnel only. To reduce the risk of electric shock, do not perform any servicing other than that contained in the service instructions unless you are qualified to do so.

A. Introduction

This section on troubleshooting provides a description of potential malfunctions, their cause, location and correction. A Troubleshooting Reference Chart listing the most probable causes and corrections follows the general text.

IMPORTANT NOTE: All repairs to the fire suppression system (If Supplied) must be completed by the authorized fire control contractor.

The electronic air cleaner is the unit within the system that has the highest efficiency collection rating. When a malfunction occurs, the outage is usually found in the electrical secondary circuit in the ionizing/collecting cell(s).

Indicating lights (LEDs) are installed in the face of the power supply enclosure on the KES ionizer/collector cell access door and provided with the Trion optional remote mounted control box. These lights monitor the electrical operation of each power supply and the ionizer(s) and collecting cell(s) they energize. The KES-2 requires (1) power supply to energize (1) ionizer and (2) collector cells. The 4000 CFM KES-4 requires (2) power supplies to energize (2) ionizers and (4) collector cells.

Other than the basic hand tools, it is advantageous to have a volt meter with a 20 KVDC high voltage probe.

B. Secondary Short Circuit

The most common outage is a short in the secondary circuit, and is best located through the process of elimination. Symptoms are a flickering indicating light accompanied by an arcing noise in the ionizer(s) and collecting cell(s), or an indicating light that is not glowing. A flickering light with an arcing noise is an indication of a high resistance short circuit and a light that is not glowing is an indication of a dead short. (A light that is not glowing can also be an indication of an open circuit in the primary circuit. Refer to the paragraph on open circuits page 10.) The short may be in the power supply, insulated high voltage contact on the access door, ionizer(s), or collecting cell(s). To isolate the short to any one of these three components, proceed as follows:

WARNING!
When safety interlock devices are closed, do not come in contact with high voltage components. The operating output from the high voltage power supply(s) is 13,000 VDC and 6 mA to 11.0 mA.

When the power supply(s) is de-energized there is a 20 second delay for the voltage to decay. Always short from ground to a point of high voltage with a well insulated jumper wire or an insulated handled screwdriver to bleed off any remaining residual charge.

IMPORTANT NOTE: To perform this troubleshooting step, it will be necessary to close the ionizer/collector cell access door and re-connect the flex cable connector to the flange-mounted connector on the access door. This will re-energize the power supply(s). The panel on the ionizer/collector cell access door enclosure will also need to be removed.

1. Disconnect both high voltage leads from their respective terminals in the power supply and support them away from any point of contact.
2. Energize the power supply:
 - a. If the light still flickers or does not glow the trouble is indicated to be in the power supply. Replace the power supply in its entirety.
 - b. If the light glows steady with the leads disconnected, the power supply is indicated to be normal.

3. Next reconnect both high voltage leads to their respective terminals inside the power supply and disconnect them at the insulated door contacts for the ionizer(s) and collecting cell(s). Support them away from any point of contact and energize the power supply.
 - a. If either high voltage lead is defective the light will indicate the trouble. Each lead may then be checked separately by disconnecting them, one at a time, from their respective terminals at the power supply. When a lead is found to be defective, replace it in its entirety. Do not repair or splice.
 - b. If the light glows steady with the leads disconnected from the insulated door contact for the ionizer(s) and collecting cell(s), the trouble is then indicated to be in the ionizer(s) or collecting cell(s). The trouble can then be isolated to the ionizer section or collector cell section and then to an individual ionizer or collector cell as follows:
4. First determine if the short is in the ionizer section or the collecting section by connecting each high voltage lead to its respective section, one at a time, and energizing the power pack. (The lead not connected must be supported away from any point of contact.) The short symptoms will still exist for the section in which the short is located.
5. When the short is isolated to either the ionizer or collector cell section, remove all the ionizers or collectors cells in that section and visually check each for the following:
 - a. If the short is in the ionizer section look for a broken or defective insulator or a broken ionizer wire.
 - b. If the short is in the collector section look for a large piece of foreign material bridging the collector plates or a

defective insulator.

C. Open Circuits

Although open circuits can occur in the secondary they usually take place in the primary. If the unit contains only one power supply and the indicating light does not glow the outage is probably one of the following:

1. Supply line power to the power supply(s) disconnected. Reconnect.
2. Main disconnect/access door interlock on KES unscrewed. Close access door and insert flex cable connector from junction box into flange- mounted connector on access door. Screw connectors together.
3. Blown in-line fuse located on the power supply circuit board. Replace power supply.
4. Outage in the power supply. Look for charred or burned components or a loose wiring connection. Replace power supply or reconnect wiring.
5. Defective indicating light. Replace light.

7. Spare Parts

Recommended spare part quantities are usually based on the unit size and the amount of units per installation. For specific recommendations, consult the Trion factory or nearest Sales Office at 919-775-2201. Consideration however, should be given to stocking the following components:

<u>DESCRIPTION</u>	<u>QTY.</u>
PWM Power Supply	1
Ionizer	2
Collector cell	4
Cell Insulators	6
LED	1

Part Numbers are not listed as they are subject to change. Always state Unit Model and Serial Numbers when ordering parts.

Troubleshooting Reference Chart

PROBLEM/ SYMPTOM	PROBABLE CAUSE	LOCATION	REASON - CORRECTION
Indicating Light Not Glowing	Short Circuit	Ionizing Section	<ol style="list-style-type: none"> 1. Dirty insulator(s) – Clean 2. Defective insulator(s) – Replace 3. Broken ionizer wire 4. Foreign Object Between Ionizing Bar and Ground electrode - Remove
		Collecting Section of Cell	<ol style="list-style-type: none"> 1. Dirty insulator(s) - Clean 2. Defective insulator(s) – Replace 3. Foreign Material Bridging Plates - Remove 4. Bent Plates – Straighten or Replace
		High Voltage Leads	<ol style="list-style-type: none"> 1. Disconnected High Voltage Lead Contacting Ground - Reconnect 2. Defective Lead/Insulation Breakdown – Replace Entire Lead
		Power Supply	Charred/Overheated Components – Replace Power Supply
Indicating Light Not Glowing	Open Circuit	Remote Mounted Control Box	<ol style="list-style-type: none"> 1. Disconnected Supply Line Power – Reconnect 2. Faulty indicating Light - Replace
		Power Supply	<ol style="list-style-type: none"> 1. Blown In-line Fuse – Replace Power Supply 2. Disconnected Wire – Replace 3. Charred/Over Heated Components – Replace Power Supply
		Electronic Air Cleaner Housing	<ol style="list-style-type: none"> 1. Electrical Interlock Connector Not Closed – Close Access Door and screw connectors together 2. Junction Box wiring faulty – Check and correct 3. Faulty Electrical Interlock Connector - Replace
Indicating Light Flickering	High Resistance Short	High Voltage Circuit	<ol style="list-style-type: none"> 1. Ionizer High Voltage Lead Connected to Collector Section and Collector Lead to Ionizer – Reconnect Leads 2. Loose or Disconnect high Voltage Lead-Tighten or Reconnect 3. Loose or Defective Intercell Connection (on Multicell Units) – Tighten or Replace 4. Foreign Object Adrift in Ionizer or Collector – Remove 5. Dirty Cells – Remove, clean and replace.

FIGURE – 2
Typical Outdoor Installation

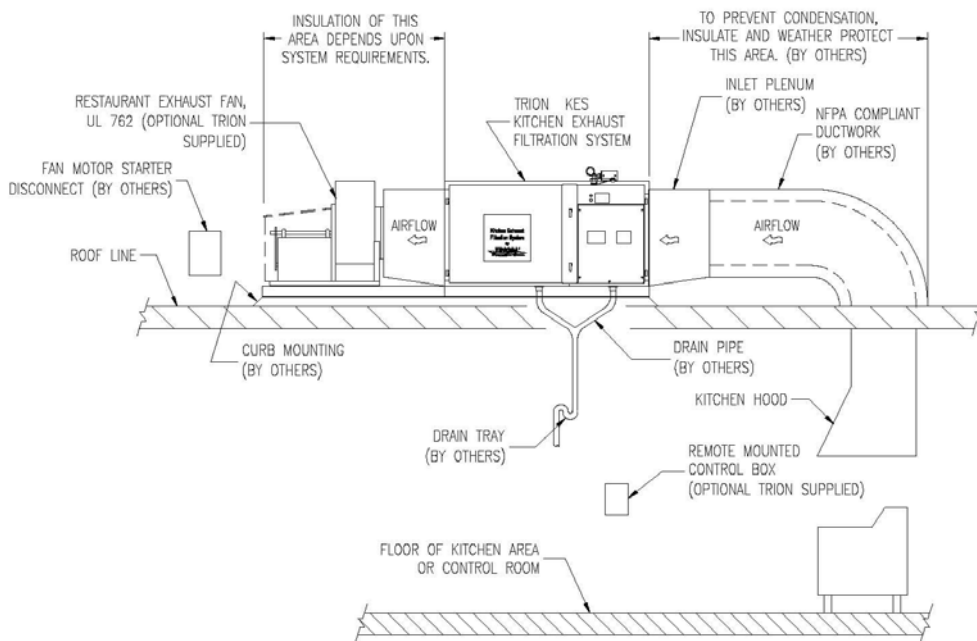

FIGURE – 3
Field Wiring-Junction Box

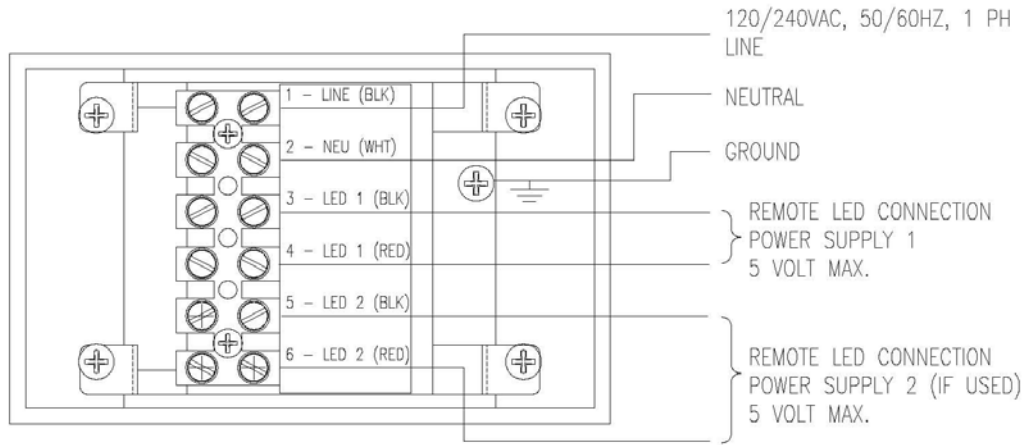

FIGURE – 4
Wiring Diagram
KES-2

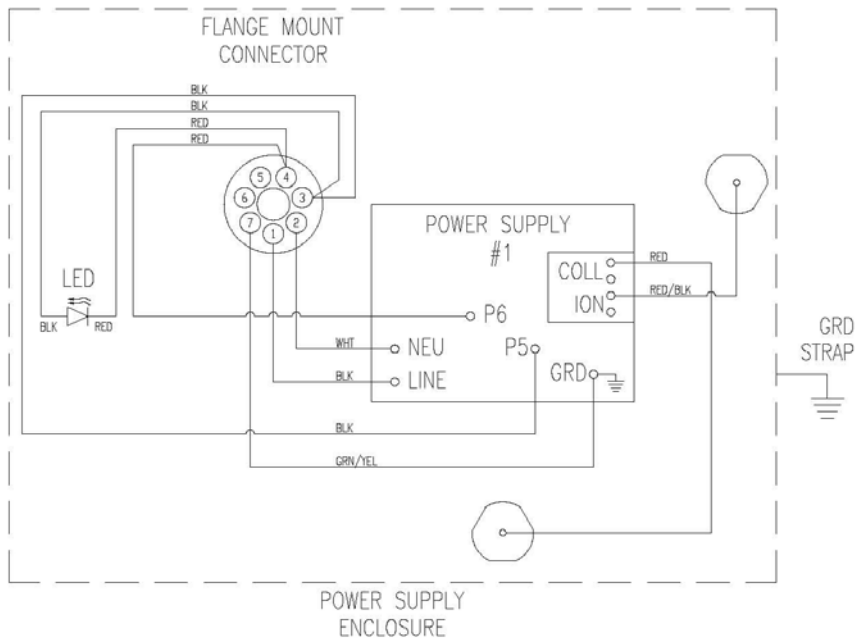
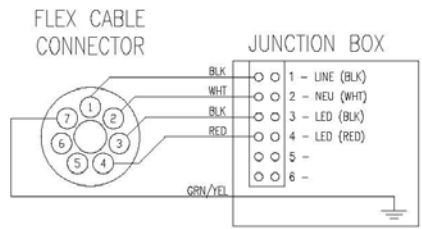

FIGURE – 5
Wiring Diagram
KES-4

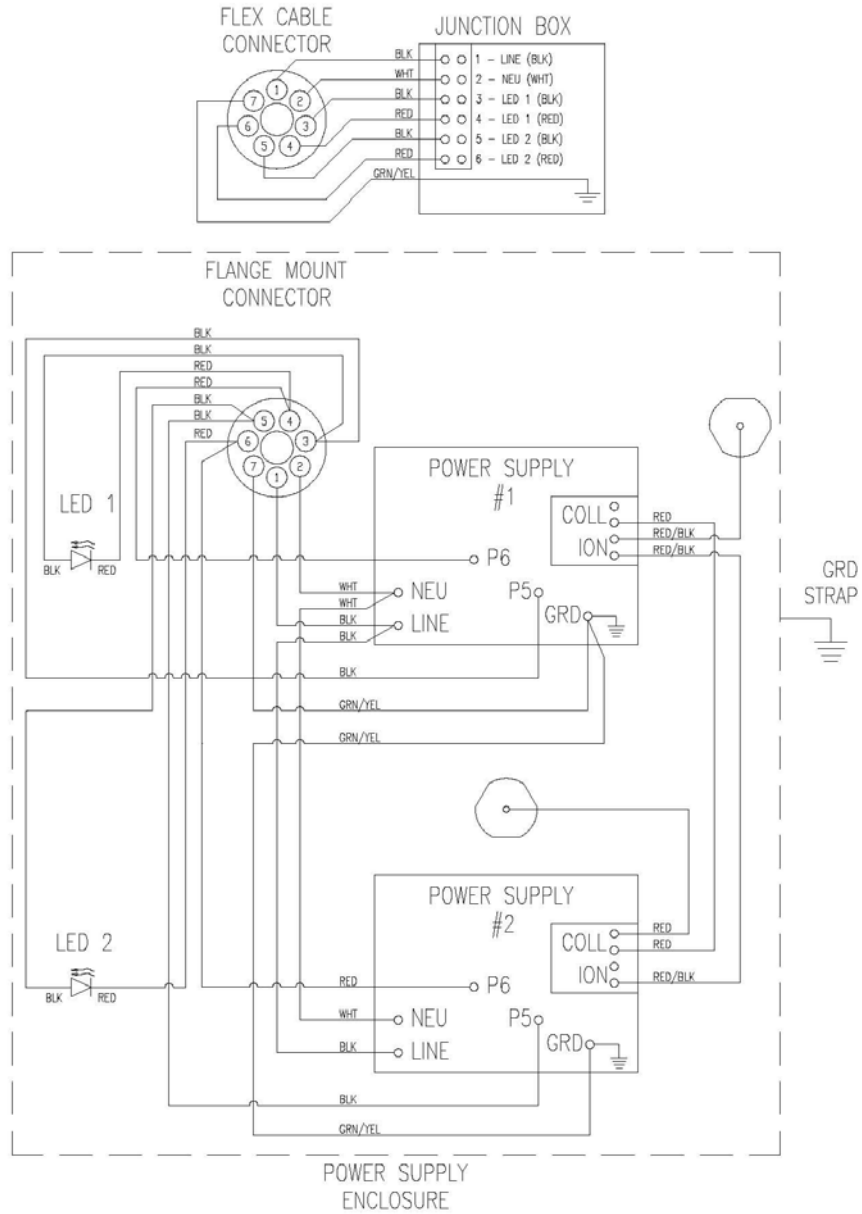
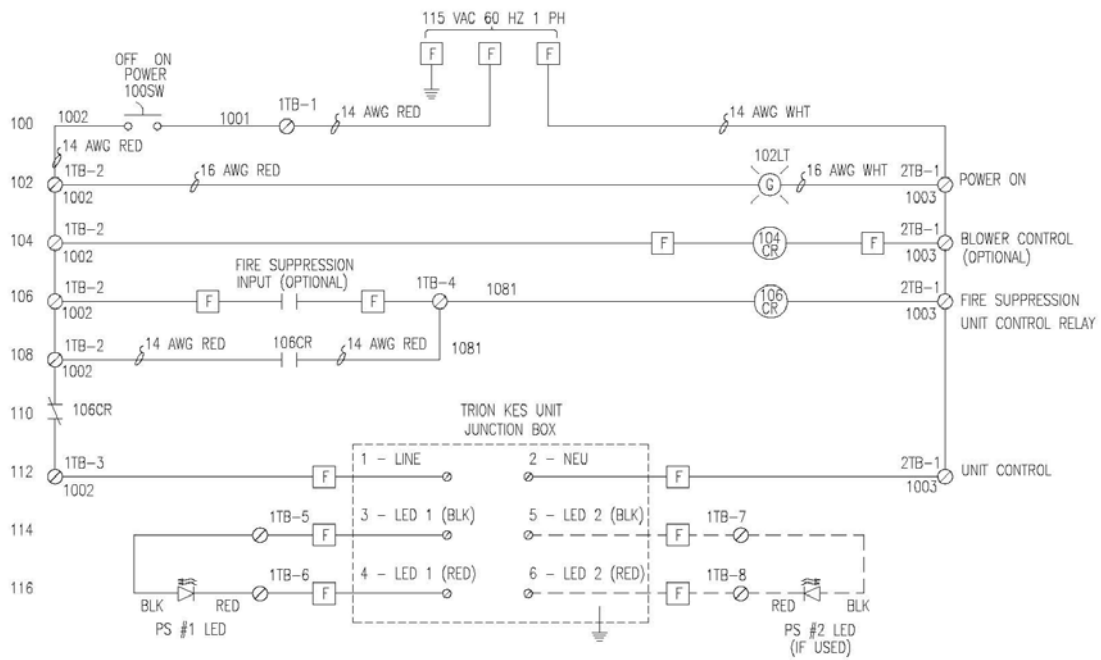

FIGURE – 6
Remote Mounted Control Box
Schematic



NOTES:

- 1) DENOTES TERMINAL CONNECTIONS IN REMOTE MOUNTED CONTROL BOX.
- 2) DENOTES FIELD WIRING BETWEEN REMOTE MOUNTED CONTROL BOX AND EXTERNAL DEVICES
- 3) DENOTES TERMINAL CONNECTIONS IN TRION KES UNIT JUNCTION BOX

FIGURE – 7
Parts List
Access Door Enclosure Components

REF. NO.	DESCRIPTION	TRION PART NO.
1	HV CIRCUIT BOARD ASSEMBLY	448740-001
2	CIRCUIT BOARD GUIDE	123480-001
3	DRAW LATCH	334562-005
4	STAND-OFF INSULATOR, MODIFIED	353228-001
5	FIRESTOP CAULKING	150694-001
6	WIRING DIAGRAM (2000 CFM – SEE FIG. 4)	257178-001
7	WIRING DIAGRAM (4000 CFM – SEE FIG. 5)	257175-001
8	HV WIRE ASS'Y. (COLL. JUMPER 4000 CFM)	257046-101
9	HV WIRE ASS'Y. (COLL. – P/S 2, 4000 CFM)	257046-102
10	HV WIRE ASS'Y. (ION. JUMPER 4000 CFM)	257046-103
11	HV WIRE ASS'Y. (ION. – P/S 1, 2000/4000 CFM)	257046-104
12	HV WIRE ASS'Y. (COLL. – P/S 2, 4000 CFM)	257046-105
13	NEMA 12 LED	257177-001
14	FLANGE MTG. CONNECTOR	257037-003
15	SEALING CAP ASSEMBLY TOOL	257037-004
16	GASKET	224779-015

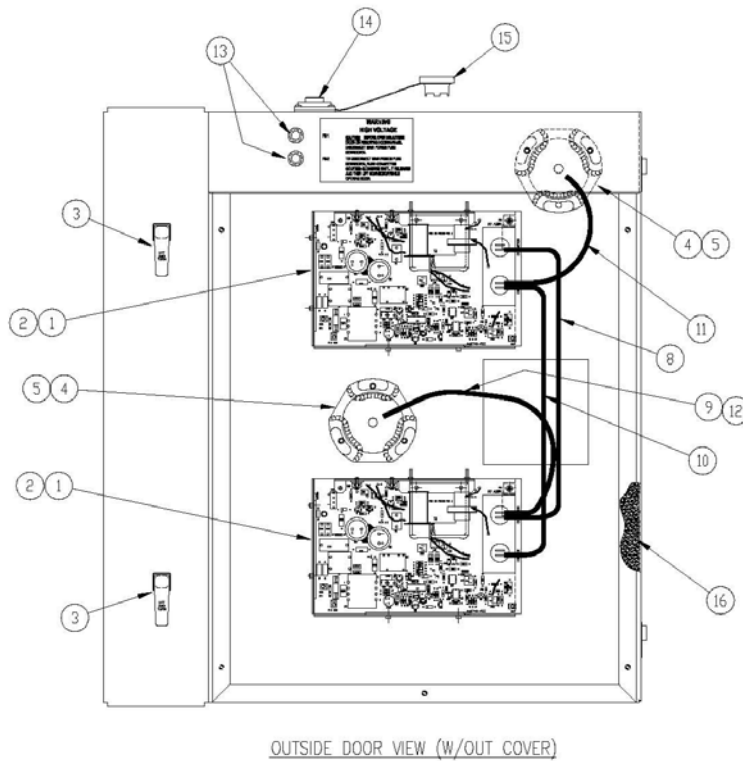
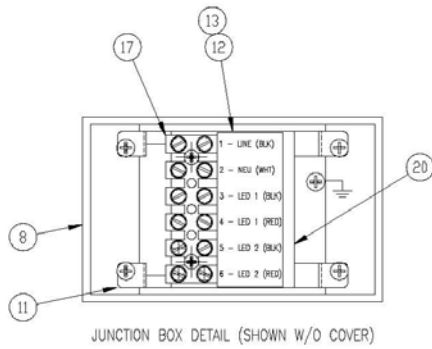

FIGURE – 8

Parts List

KES Cabinet Components

REF. NO.	DESCRIPTION	TRION PART NO.
1	IONIZER CELL	457200-001
2	COLLECTOR CELL	457300-001
3	PERFORATED BAFFLE	344601-004
4	FLEX CABLE CONNECTOR	257037-001
5	SEALING CAP/ASSEMBLY TOOL	257037-002
6	CABLE GLAND	257037-005
7	NYLON, LIQUID TIGHT CONNECTOR	128077-003
8	JUNCTION BOX	60000-0008-01
9	JUNCTION BOX COVER	60000-0008-02
10	POWER CORD	145797-002
11	TERMINAL BLOCK MTC. BRACKET	257048-001
12	TERMINAL BLOCK LABEL	257185-001
13	TERMINAL BLOCK LABEL	257185-002
14	IOS MANUAL (NOT SHOWN)	257045-001
15	GROUND STRAP ASSEMBLY	257184-001
16	SAFETY – FILTER CLIP	257182-001
17	TERMINAL BLOCK	EST-1124
18	DOOR GASKET (NOT SHOWN)	224779-015
19	ALUMINUM MESH AIR FILTER	224451-025
20	INSULATOR, NOMEX	157180-001



OPTIONAL CARBON TRAYS
TRION P/N 357036-001
(QTY. 16 REQUIRED
FOR KES 4 UNIT)
(QTY. 8 REQUIRED
FOR KES 2 UNIT)

OPTIONAL PLEATED MEDIA FILTER
TRION P/N 357035-001
(QTY. 2 REQUIRED FOR KES 4 UNIT)
(QTY. 1 REQUIRED FOR KES 2 UNIT)

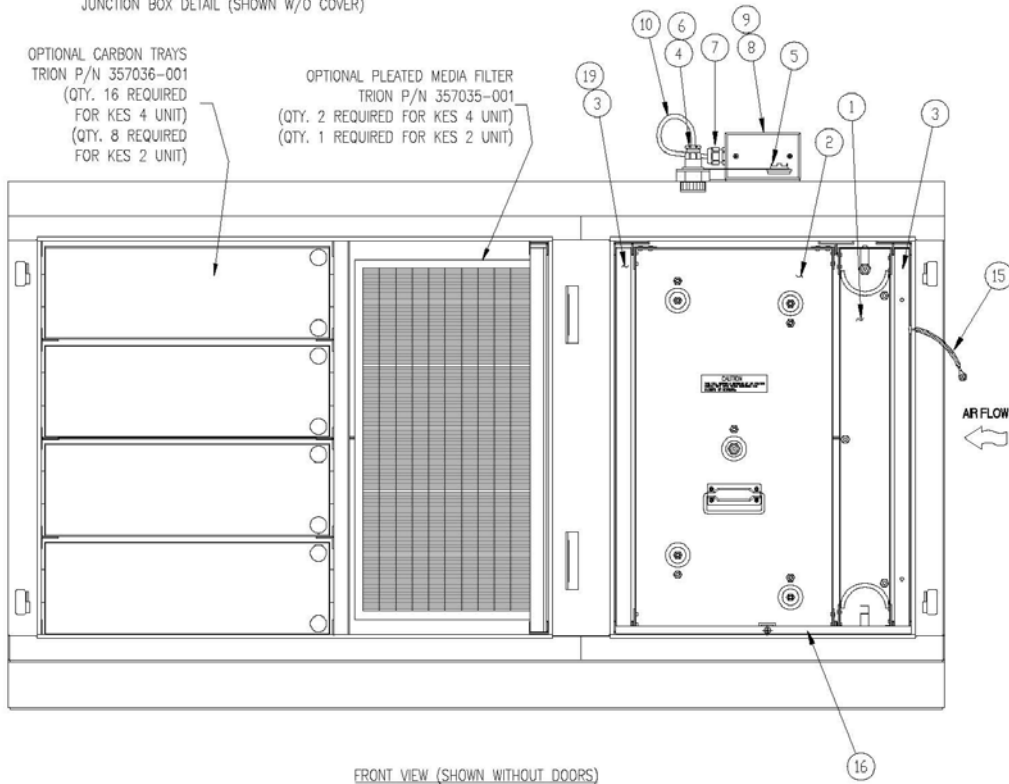

Contact Information

Headquarters

Trion, Inc.

101 McNeill Road
Sanford, NC 27330
Tel. 800 884 0002
Fax 919 777 6399
Email: sales@trioninc.com

Trion LTD.

The Cavendish Center
Winnall Close
Winchester, Hampshire
SO23 OLB, UK
Tel. 440 1962 840465
Fax 44 0 1962 828619
Email: info@trion.co.uk

Trion GmbH

Boscstr. 60
D-50171, Kerpen
Germany
Tel. 49 0 2237 922 103
Fax 49 0 2237 922 104
Email: info@trion-deutschland.de

Fedders International

No. 728 Fuzhou Road
Rm. 3002-3005
Raffles City Office Tower
Shanghai, P.R. China, 200001
Tel. 86 21 63403232
Fax 86 21 63403867
Email: InfoChina@Fedders.com

Fedders International

Air Conditioning

A-30, Chintels House
Kalish Colony
New Delhi
India 110048
Tel. 91 11 5173 0730
Fax 91 11 5173 0743
Email: InfoIndia@Fedders.com

Fedders International, Inc.

128 Joo Seng Road
#05-01
DP Computers Building
Singapore 368 356
Tel. 65 6286 0995
Fax 65 6286 0859
Email: InfoAsia@Fedders.com

