

NOTES:

- 1) THE BACKFLOW PREVENTER MUST BE LOCATED UPSTREAM FROM THE DETERGENT FEEDER LINE CONNECTION AND 1/4" STRAINER. THIS DEVICE SHOULD BE CONTINUOUS PRESSURE TYPE AND INSTALLED IN ACCORDANCE WITH ALL APPLICABLE PLUMBING CODE REQUIREMENTS.
- 2) WASH WATER REQUIREMENTS: 21.3 GPM @ 50 PSI
- 3) PIPING AND PRESSURE GAUGE SHOWN BY PHANTOM LINES IN SYSTEM PLUMBING SCHEMATIC SUPPLIED BY OTHERS.
- 4) AVERAGE WASH WATER CONSUMPTION: 149 GALLONS
- 5) SYSTEM WEIGHT (ESTIMATED) WITH POWER PACKS AND CONTROLS: 4,600 LBS.
- 6) UNIT SHOWN WITH RIGHT HAND ACCESS.
- 7) DRAIN LINE TRAP MUST PROVIDE SUFFICIENT WATER COLUMN TO OVERCOME THE INTERNAL STATIC PRESSURE OF THE AIR HANDLING SYSTEM IN WHICH THE MODEL 75 IS INSTALLED.
- 8) ALLOW FOR MAXIMUM AVAILABLE SLOPE ON DRAIN LINES. INSUFFICIENT SLOPE ON DRAIN LINES WILL RESULT IN POOR DRAINAGE, POOLING OF LIQUID IN THE CABINETS, AND SYSTEM FAILURE.
- 9) INJECT DETERGENT LINE INTO MAIN WATER LINE AS CLOSE AS POSSIBLE AND UPSTREAM FROM THE MODEL 75.
- 10) PROTECT ALL WASH WATER AND PLUMBING COMPONENTS THAT ARE SUBJECT TO FREEZING.
- 11) IT IS RECOMMENDED THAT HOT WATER (MIN. 120°F) BE USED FOR A MORE EFFICIENT WASH CYCLE. HOT WATER TANKS SHOULD BE LOCATED AS CLOSE AS POSSIBLE TO THE UNIT BEING WASHED AND SUFFICIENT PIPING MUST BE PROVIDED SO THE WATER FLOW IS NOT RESTRICTED NOR WATER PRESSURE APPRECIABLY REDUCED.
- 12) SOLENOID ON VALVE MUST BE MOUNTED VERTICAL, AND UPRIGHT.
- 13) MODEL 75-204-04 (1st PASS) SUPPLIED WITH PERFORATED PLATE PREFILTER. MODEL 75-204-04 (2nd PASS) SUPPLIED WITH METAL MESH AFTERFILTER.
- 14) FAN RATING: 8,000 CFM @ 4.0" TOTAL STATIC PRESSURE.
- 15) THIS SYSTEM REQUIRES TWO ELECTRICAL CIRCUITS: CONTROL - 120VAC/60HZ/1PH @ 30 AMP. MAX. BLOWER MOTOR - 10 HP, 230VAC/60HZ/3PH RATED @ 28 FLA
- 16) TRION SYSTEM PROVIDED WITH ANSUL R-102 FIRE SUPPRESSION SYSTEM.

- ETL LISTING TO UL 867 "ELECTROSTATIC AIR CLEANERS"
- UL LISTED YXYS & YXYS7 (CANADA) "HOOD AND DUCT ACCESSORIES"
- FANS FOR KITCHEN EXHAUST SYSTEMS UL LISTED UL762 "POWER ROOF VENTILATORS FOR RESTAURANT EXHAUST APPLIANCES"
- DESIGNED IN ACCORDANCE WITH THE RECOMMENDED PRACTICES OF NFPA 96 STANDARD FOR VENTILATION CONTROL AND FIRE PROTECTION OF COMMERCIAL COOKING OPERATIONS.

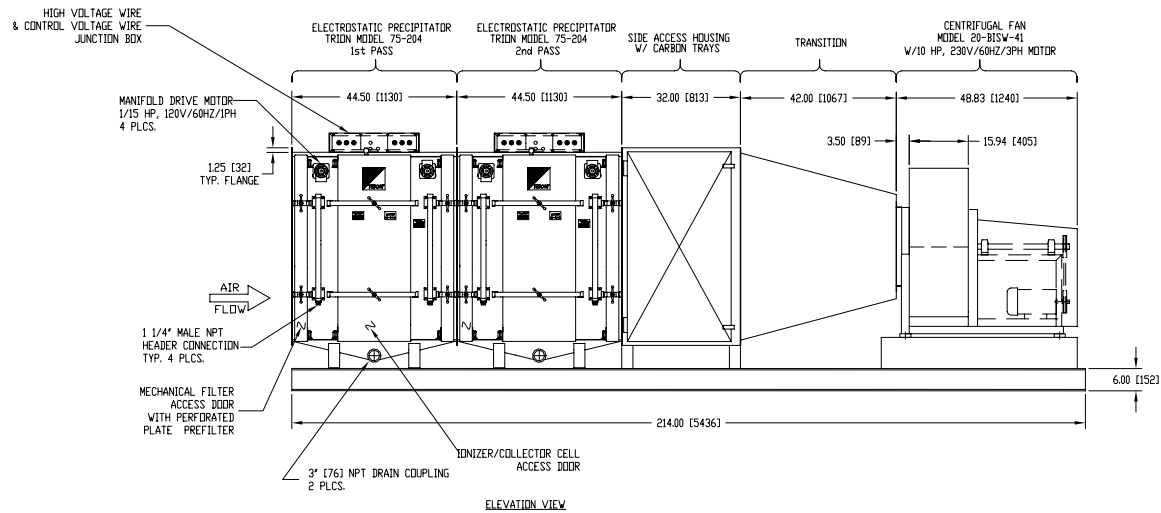
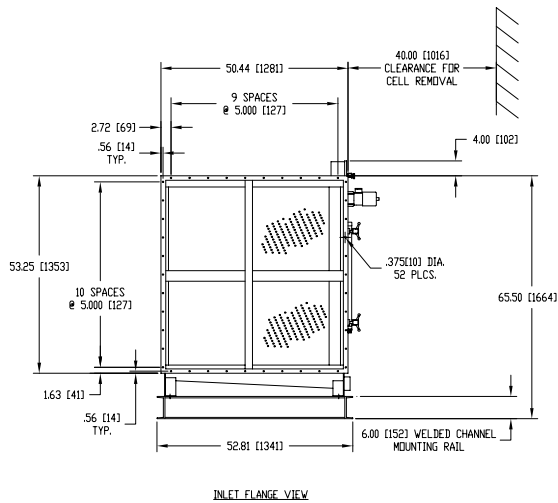
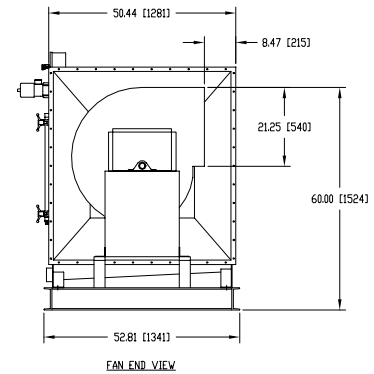
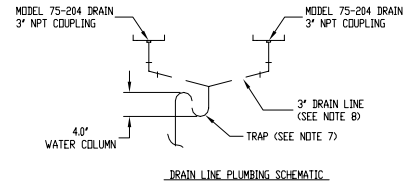
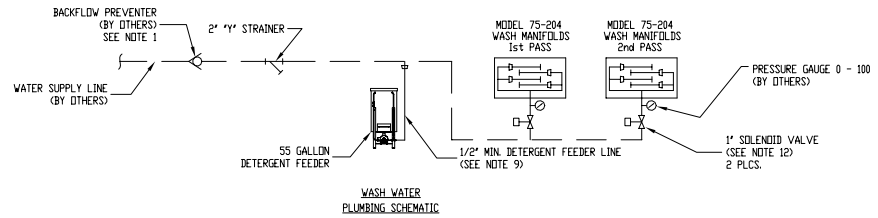

CD-

		UNLESS OTHERWISE SPECIFIED USE			MODEL 75-204/204-04		D	SAMPLE DWG	SHT
SCALE	1/16"=1'	± DEC. PLACE	± DEC. PLACE	± DEC. PLACE	± DEC. PLACE	TRION®			
NEXT ASSY	USED ON	DR.	APP.	CHKD.	DATE				
APPLICATION	DATE	DATE	DATE	DATE	DATE				